

TNC Conn. Series

Material & Finish

Body: Zinc Alloy Nickel Plating

Insulator: DELRIN

Center Contact : Brass , Gold Plating

Mounting Post: Phosphor Bronze / Tin Plating



TNCS001-F  GW-L

5:50 Ω 7:75 Ω

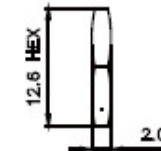
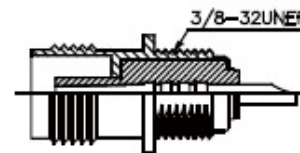
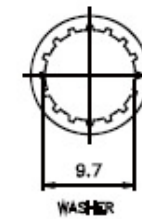
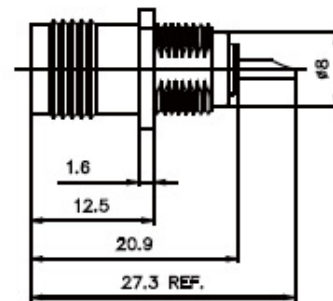
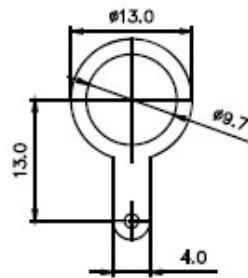

HEX. NUT



RECOMMENDED MOUNTING HOLE
MAXIMUM PANEL THICKNESS: 6.5MM

TOPTEK
HARDWARE ELECTRONIC COMPONENTS



www.toptek-co.com